

THIS DRAWING IS UNPUBLISHED. RELEASED FOR PUBLICATION
 © COPYRIGHT - By - ALL RIGHTS RESERVED.

LOC		DIST		REVISIONS			
P	LTR	DESCRIPTION		DATE	DWN	APVD	
CM	0	J		REVISED PER ECR-15-010337	23JUL2015	RK	SC

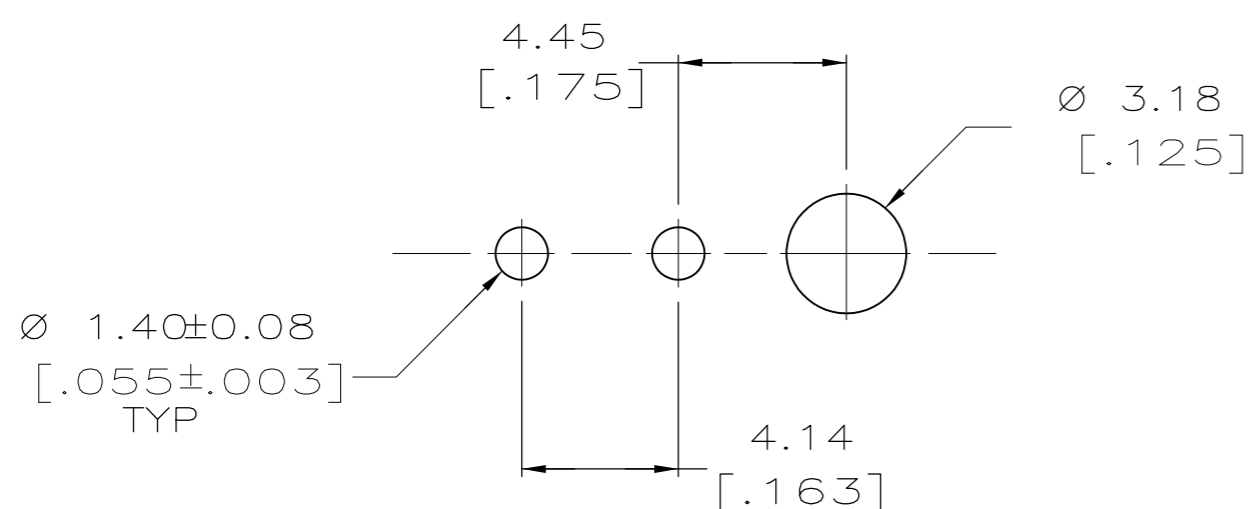
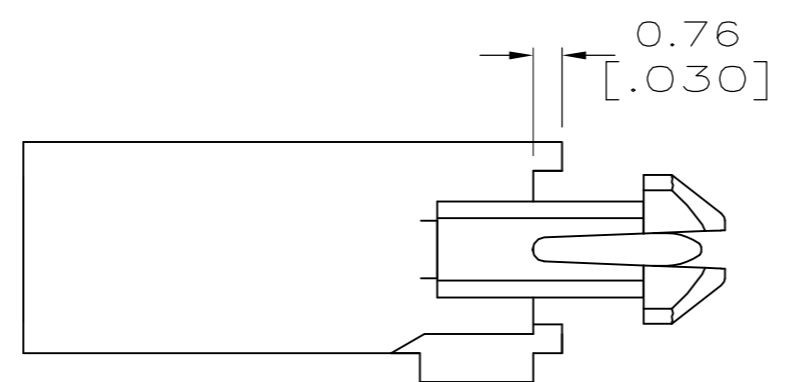
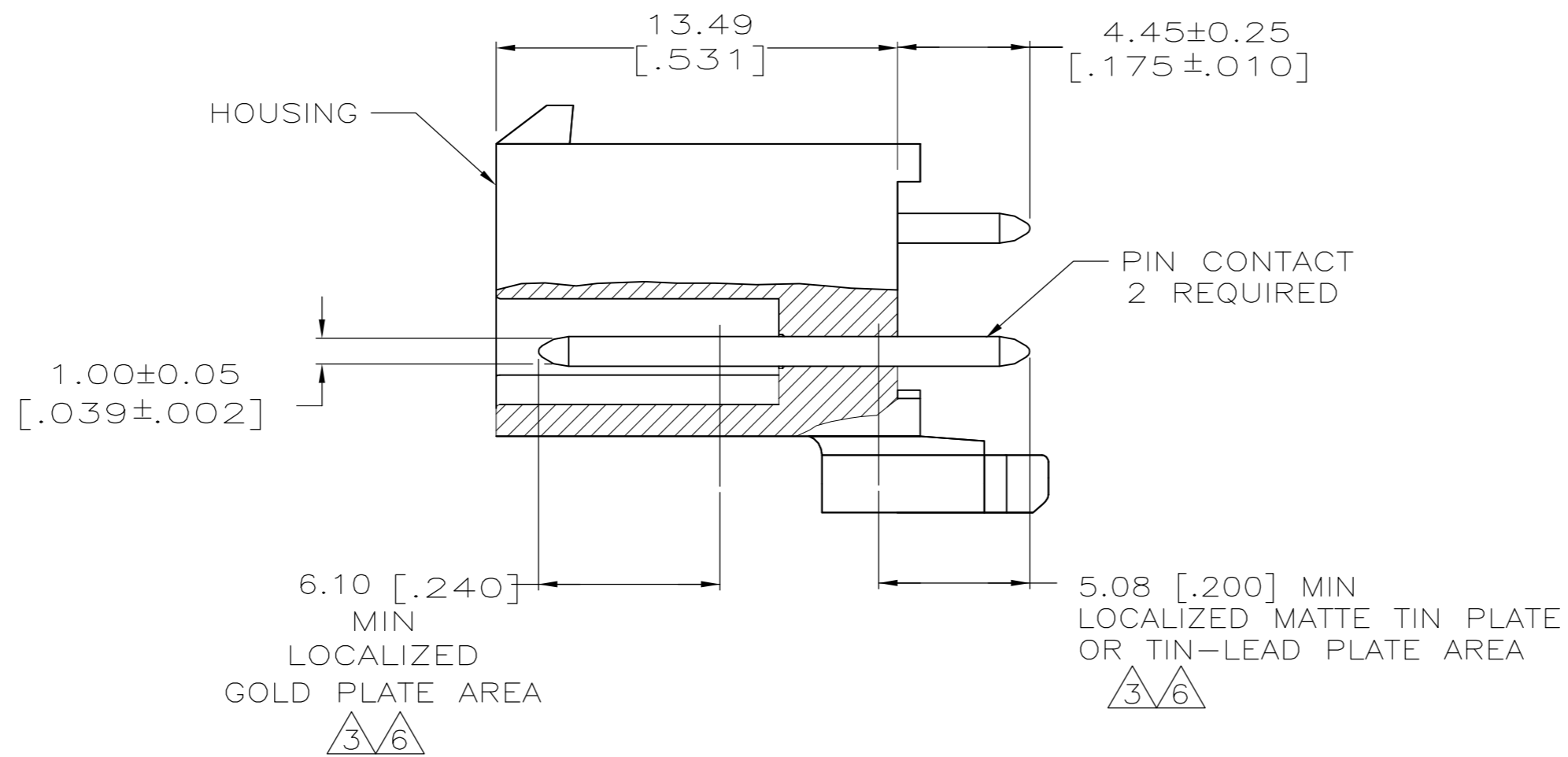
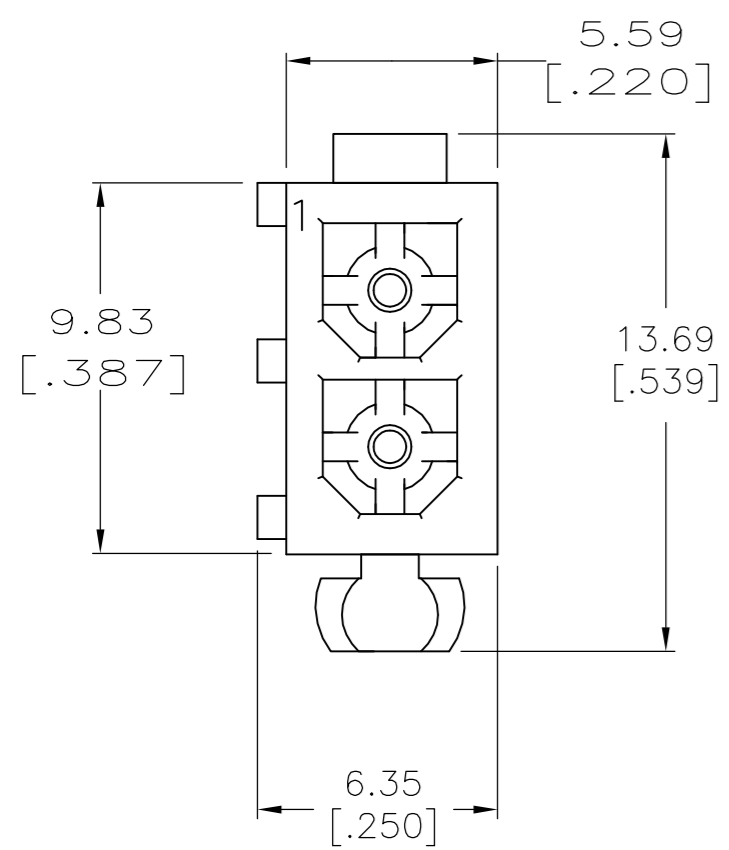

RECOMMENDED LAYOUT FOR 1.57 [.062] THICK BOARD
 TOLERANCES NON-ACCUMULATIVE

- PINS TO COMPLY WITH AMP SOLDERABILITY SPEC. 109-11-3.
- DIMENSIONS SHOWN IN BRACKETS ARE IN INCHES.
- 0.00076 [.000030] MIN GOLD PLATE IN THE LOCALIZED GOLD PLATE AREA, 0.00381 [.000150] MATTE TIN LEAD IN THE LOCALIZED TIN LEAD PLATE AREA, BOTH OVER 0.00127 [.000050] MIN NICKEL.
- 0.00381 [.000150] MATTE TIN LEAD OVER 0.00127 [.000050] MIN NICKEL ENTIRE LENGTH OF PIN.
- 0.00381 [.000150] MATTE TIN OVER 0.00127 [.000050] MIN NICKEL ENTIRE LENGTH OF PIN.
- 0.00076 [.000030] MIN GOLD PLATE IN THE LOCALIZED GOLD PLATE AREA, 0.00381 [.000150] MATTE TIN LEAD IN THE LOCALIZED TIN LEAD PLATE AREA, BOTH OVER 0.00127 [.000050] MIN NICKEL.

BRASS	6	NYLON, UL94V-0	WHITE	1-770872-1
BRASS	5	NYLON, UL94V-0	WHITE	1-770872-0
BRASS	3	NYLON, UL94V-0	WHITE	770872-2
BRASS	4	NYLON, UL94V-0	WHITE	770872-1
MATERIAL	FINISH	MATERIAL	COLOR	PART NO.

THIS DRAWING IS A CONTROLLED DOCUMENT.		DWN	S CARPENTER	08JUN05	 TE Connectivity
DIMENSIONS: mm		CHK	R JONES	28JUL2003	
TOLERANCES UNLESS OTHERWISE SPECIFIED:		APVD	R JONES	28JUL2003	
0 PLC ± - 1 PLC ± - 2 PLC ± 0.13 3 PLC ± - 4 PLC ± - ANGLES ± -		PRODUCT SPEC	NAME		
MATERIAL	FINISH	WEIGHT	A2 00779 C=770872		RESTRICTED TO
CUSTOMER DRAWING		SCALE	5:1	SHEET	1 of 1